

Ansicht F

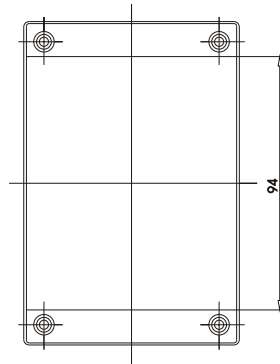

\* = Mass durch Formkonzilität nach unten verringert.  
Frei-mass - Toleranz nach GTA 13/5 DIN 1688

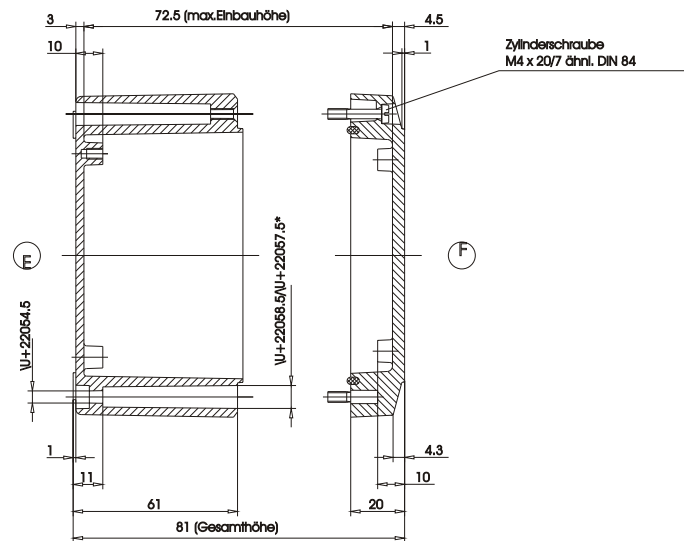
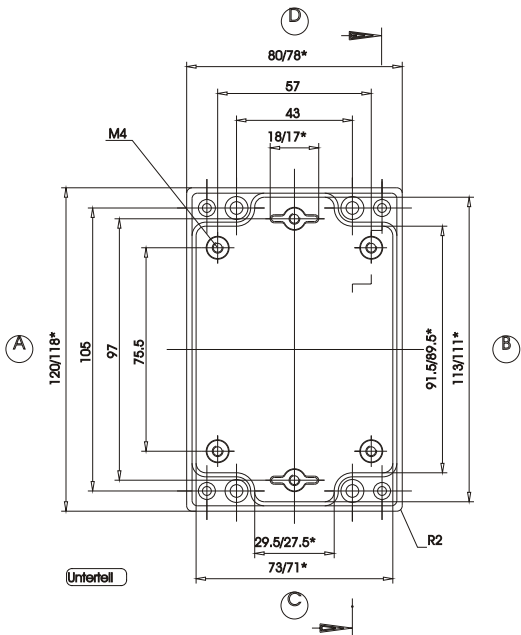
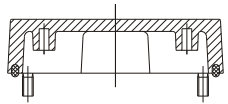

GH02AL005/010